

## Northwest Woodworkers Association

# THE SAWDUST NEWS



March 2015

<http://www.nwoodworkers.org>

An association for woodworkers of all skill levels to share their common interest

## The Next Meeting

**Date:** Thursday, April 30, 2015, 6:30 PM

**Location:** Woodcraft Supply

5963 Corson S.

Seattle, WA 98125

**Program Highlight:** Mega Show 'N' Tell

This will be an opportunity for all of our members to display their current woodworking projects – either completed or in process. Bring along a thumb drive with your project photos, too.

## March 2015 Meeting Highlights

*Newsletter Photos by Scott Wilson*

*Meeting Notes by Chris Yee*



The March 2015 meeting of the Northwest Woodworkers Association was held on Thursday, March 26, 2015 at Rockler - Northgate with 23 members and guests present.

We want to express our appreciation to the management and staff at **Rockler – Northgate** for providing a wonderful venue for this meeting and for extending their store hours to accommodate our extended length program.

## *Special Program Presentation*

### **The Seattle Tool Library by Joel Gregory**



We were treated to an interesting presentation by Joel Gregory regarding relatively new program in Seattle called the Seattle Tool Library. As the name implies, this program is similar to a book lending library in that all sorts of hand and power tools are available for members to borrow, **free of charge**. The program was made possible by a \$50,000 grant from the Seattle Department of Neighborhoods, which included funding for a full time Coordinator – the rest of the staff and supporters are unpaid volunteers.

The Tool Library currently has some 3500 tools available for lending. The tools cover a wide range of applications, including automotive, kitchen, woodworking, yard care, home maintenance and remodeling, to name just a few.

The tools are donated to the Tool Library – some from folks who are downsizing or just don't need them anymore, some from estates, and other sources. They prefer to the tools to be in working order and have factory supplied safety guarding in place, although they will perform maintenance on the tools and do minor repairs. Joel mentioned that donated tools do qualify for a tax exemption, as the Tool Library is a non-profit organization. He also mentioned that they **do not** accept any gasoline powered tools, due to the fuel handling/storage liabilities involved.

In the short time the Tool Library has been in existence, it has been an outstanding success. Typically there are up to 1500 loans per month – and they have made more than 17,000 loans since 2013! Wow!! In addition, Joel reported that they have had no tool losses! One of our Association members reported that a friend in Seattle, having recently moved into a house from an apartment, frequently borrows tools to maintain/improve his home, perform yard work, etc. and finds the program a real blessing.

Interestingly enough, the most popular borrowed tool is a tamper, with chainsaws, table saws, trimmers, drill presses, and power washers also popular items. Typically, the items are borrowed for a period of one week. One of their unique tools is a cider press – which the Tool Library uses one day each Fall to make apple cider, using donated apples. This tool is also available for lending – and Joel says it is really popular in the Fall.

The Tool Library membership costs between \$20 - \$40 per year, with a \$250 lifetime membership available. To date they have some 2000 members, 80% of whom borrow tools.



In addition to their tool lending activities, they also dedicate one night a month to fixing the Library tools, and sponsor a craft day, where folks bring scrap materials and work with kids on projects. They also offer classes on sewing, project building, tool use and safety, etc.

In addition to the NE Seattle Tool Library, ( <http://neseattletoolibrary.org> ) there are two other tool libraries available in other parts of Seattle: West Seattle Tool Library (<http://wstools.org> ) and Phinney Neighborhood Center ( <http://www.phinneycenter.org/tools> )

Thanks Joel, for educating us about this exciting program. Perhaps some of our members will sort through their tool collections and see if they could come up with some tools that could be donated to your program, especially those dusty old unused tools ***“That I just might need some day”***. This certainly a worthy cause folks.

## ***Upcoming Events***

**April 2015 Meeting** – The **April** meeting will be held at **Woodcraft Supply**, on **Thursday, April 30<sup>th</sup>, 2015**. This will be a **Mega Show ‘N’ Tell** event, so save up your projects and bring them along to share. To aid in your project description, please bring along in-process project photos and drawings or sketches on a digital thumb drive, as well as any unusual tools and jigs used in the project. This is a grand opportunity to showcase your woodworking skills, knowledge, and expertise and help all of us expand our understanding and appreciation of this marvelous woodworking hobby. Bring your project to contribute to the fun! The more the merrier!!

**May 2015 Meeting** – The **May** meeting will be held at **Rockler – Northgate** on **Thursday, May 28, 2015**. The final details of the meeting will be in next month’s newsletter. However, we can say that this will be a really interesting presentation by a guest speaker regarding the techniques for successful woodworking project photography using your point and shoot cameras and simple, low cost materials. Don’t miss this one!!

## ***Special Note***

The **Steering Committee (SC)** has been working for some time to develop a viable way to improve our capability to display and view photos and illustrations of our projects, visual presentations, etc. The video projector and screen, which **Woodcraft** has generously allowed us to use at our meetings there, have not provided the quality images we would like to use in our meetings. Though better, the flat screen video displays at **Rockler – Northgate** likewise do not provide the quality and size of images we desire.

So an **SC** project, spearheaded by **Bill Bond**, was launched to select and purchase a new video projector and viewing screen for the Association. We believe the new wireless state-of-the-art video projector and 80” viewing screen you saw in use at this March meeting provided outstanding results, exceeding our expectations – a worthy investment by the Association. We hope this equipment will enhance your viewing enjoyment and, better yet, the images of **your** projects and presentations.

# March 2015 Meeting Highlight The 2015 NWWA Annual 2 x 4 Challenge

This was our third 2 x 4 Challenge. As in previous years, the basic ground rule challenge was to make one or more woodworking projects from a softwood, construction grade 2 x 4. In each of the previous years, we enjoyed a wide variety of projects and this year's entries were equally entertaining and diverse, with a whole new spectrum of unique projects.



Rubber Band Rifle  
by Herb Stoops



Smart Phone Sound Amp  
by Tom Howorth



Asian Inspired Box  
by Paul Stoops

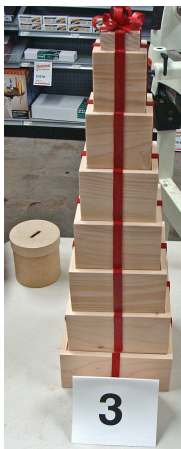

Tower of Boxes  
by Allen McCall



Stunning Bowl  
by Chris Green



Elegant Bird Feeder  
by Bill Bond

## 2015 NWWA 2 x 4 Challenge Entries

## Smart Phone Sound Amplifier – by Tom Howorth



**Tom Howorth's** entry in the Challenge was a very unique high tech project, attuned to the modern world we live in. Using his own design, somewhat fashioned after some of the available commercial models on the market today, **Tom** built a passive (i.e. no electronics) smart phone sound amplifier. This device utilizes right and left conical sound chambers connected via grooved channels to a center chamber which nests a smart phone. The small internal speakers in the smart phone transmit the sound both directions to the sound chambers, which amplify the sound levels.



He noted that he milled a bevel on the bottom of the device to tilt the phone and sound chambers slightly backward to better direct the sound.

Does it work, we wondered? To our delight, **Tom** turned on his smart phone with some music playing to give us a baseline sound level and then installed it in his passive amplifier. Wow! What a difference – from several feet away the amplified sound level was very evident! Great job, **Tom**. And what a relief it for Sr. Cits like me, who tenaciously cling to their Geezer phones, to have one of our members keeping us on the cutting edge of technology..... :-)

## Rubber Band Rifle – by Herbert Stoops



Showing us his very realistic looking Rubber Band Rifle, **Herb Stoops** explained that he had seen the project mentioned on a woodworking forum and it piqued his curiosity enough that he downloaded the free plans. One of the very unusual things about the project was that it was originally designed to be made from 4mm (0.157”) plywood – apparently a common material where the project was designed. Essentially, all of the parts were designed to be made by laminating multiple layers of the thin plywood to attain the desired thickness. To that end, the downloaded materials included excellent 3D construction drawings and a set of scaled patterns for each layer of all of the parts! This is an amazing value – the original author must have spent a lot of time making the detailed exploded assembly views and part drawings. The parts were designed to be cut out via scroll saw or similar.

Reasoning that the fastest way to make the parts from thin strips of his 2 x 4, **Herb** made a plywood pattern of each part so he could mill them on his router table. However, he discovered that the hard/soft grain patterns of the Douglas Fir stock did not lend itself to peripheral routing without excessive tearout. So instead, he used the patterns as guides to bandsaw the pieces to be laminated, smoothing the part profiles by hand and with his oscillating drum/belt sander.

**Herb** noted that the project required a lot of hand work and shaping due to the laminated construction. Also, he had some difficulties with the small parts for the internal mechanisms of the rifle because the solid wood stock was not strong enough to withstand the forces – a problem that was probably not encountered in the original design because of the strength of the plywood material.



However, he prevailed and was able to construct the working model of the rubber band rifle, with the working lever action and internal mechanisms.

He also showed us a pair of connected spare “barrels”, (making it look more like a shotgun) that he was able to fabricate using some specialized techniques on his router table with a half round bit.

**Herb** noted that the free plans and a YouTube video are may be found here:

[http://www.mediafire.com/download/nlx7691rwv2sun?LEVER-ACTION\\_RIFLE\\_MODEL\\_1873.PDF](http://www.mediafire.com/download/nlx7691rwv2sun?LEVER-ACTION_RIFLE_MODEL_1873.PDF)  
[https://www.youtube.com/watch?v=M\\_5g7f1Dfak](https://www.youtube.com/watch?v=M_5g7f1Dfak)

He also noted that because the pattern plans are metric, be sure to select the metric **A4** paper size on your printer settings instead of our standard **Letter** paper size when printing in order to produce print scale patterns.



After showing the project, Herb “loaded” the rifle with a 12” rubber band and fired it off over the heads of the group at an imaginary target, much to our delight!

Wow, am I glad to see that should the Association need one, we have a prime candidate for Sergeant-At-Arms..... :-)

### **Stunning Bowl – by Chris Green**



**Chris Green’s** Challenge entry, entitled “**Just Add Chocolate**” was another one of his delightful artistic creations. He noted that he succeeded in using up most of his 2 x 4, having only a 3” and a 9” piece left over!





The segmented bowl was made of three layers of 16 wedge shaped pieces. Great job, **Chris** – that took a lot of careful cutting and fitting to produce those nice tight fitting joints. Interestingly, he showed us a photo of his glue up – you could almost make out the part in the midst of the plethora of clamps, wedges, doo dads and what nots to hold it all together!! Guess that's why it certainly qualifies for the Challenge!

The bowl was also decorated with wood burned dots and chocolate colored buttons – or just maybe those were actually Malt Balls..... :-). The delightfully dyed center section of the bowl really set off the wood grain and the brown accents. Well done, **Chris!**

### Elegant Bird Feeder – by Bill Bond



***Third Place Winner  
2015 NWWA 2 X 4 Challenge***

**Bill Bond** designed and constructed this elaborately crafted bird feeder based upon an antique piece owned by one of his friends. The project combined many design, woodworking and metal working skills, including AutoCAD design, lathe turning, metal forming, soldering and just plain old elbow grease – and lots of hours and patience!!

In addition to the copper clad roof, working gutters and downspouts, the bird feeder was designed with a tubular port in the roof for adding food to the feeder.



In explaining the design and construction of his project, **Bill** noted that he had built a number of jigs and fixtures to assist him.

He also brought along a collection of these construction aids which varied from CAD designed templates, to holding fixtures, to metal and tubing forming jigs, and soldering fixtures.

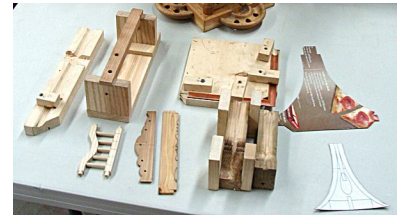

Great job, **Bill** – what a wonderful example of combining multiple skills and materials!! But I wonder, do the birds have to have reservations to eat at such an elegant place?

### Tower of Boxes – by Allen McCall

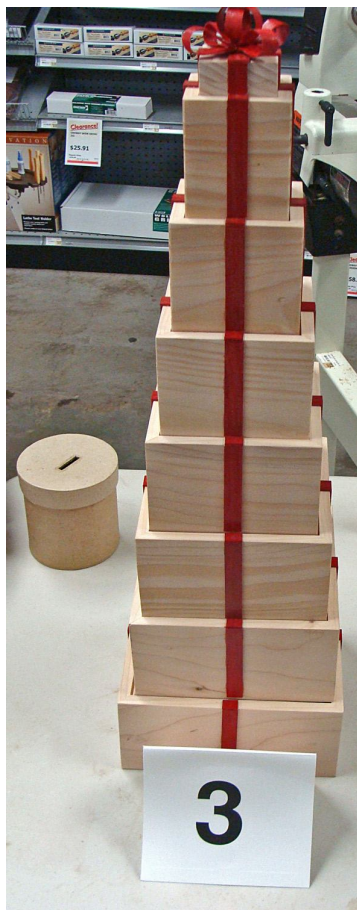

*Second Place Winner  
2015 NWWA 2 X 4 Challenge*

This cleverly designed and engineered entry by **Allen McCall** was a real delight! The beautiful contrast between the light colored boxes and the red colored wood “ribbons” that graced the sides of each box was stunning! And then the red wooden bow on top, which **Allen** said he was able to make by soaking the wooden strip in hot water, topped the project off perfectly.



However, it wasn't until **Allen** showed and explained to us how the tower of boxes was constructed that the hidden beauty of his design was revealed.

Having learned to do efficient woodworking, **Allen** designed the project to use parts with common dimensions. He milled one or more identical strips of his 2 x 4 to have the same width, thickness and configuration. These strips were subsequently cut into different length segments to form the sides of the boxes.

He rabbeted the upper edge of each stock strip to provide an interlocking lip which would just nest the top edge of the next upper box. A dado was milled near the bottom edge of the strip to enclose the bottom panel of each box. The length of each side of each square box was milled to fit inside the rabbet of the lower box, providing a constant width reveal around the top of each box. Well-crafted miter joints were used at the corners of each of the boxes.



Careful placement of the “ribbon” strip, wrapped over the upper edge of the box, further added to the illusion of a continuous “ribbon” on each side of the tower of boxes.



A marvelous example of well thought out engineering, design, and construction, **Allen!**

And you have given us some examples of clever and functional design that we can carry forth to perhaps apply on some of our own future projects.

Thanks, **Allen**, for sharing a job very, very, well done!!

## Asian Inspired Box – by Paul Stoops



***First Place Winner  
2015 NWWA 2 X 4 Challenge***

This Challenge entry had some interesting beginnings, explained **Paul Stoops**. He noted that he had seen an **Asian Inspired** bed frame on the internet some time ago and was fascinated by the sturdy but graceful shape, and the interlocking design of the frame members and the corner posts.

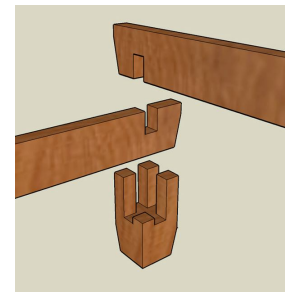

So he wondered if he could somehow miniaturize that clever corner joint design to use as a base for a jewelry box. The 2 x 4 Challenge seemed like a good opportunity to see if he could come up with a box design to use as a prototype for possible future versions that would be made from beautiful hardwoods, So a humble Douglas Fir 2 x 4 from the local Lowes store became the guinea pig for the adventure.



**Paul** noted that this **Asian Inspired Box** has several design features that may not be apparent or visible when viewing a photo of the box, which include:

- Continuous grain around the four sides of box
- The sides of the box taper at  $4.5^\circ$ , with the inside surfaces vertical
- The lid tapers on all four sides to a sculptured edge contour
- Center cut box joints made with an I-Box Jig – a technique producing a wider center pin
- The width-to-length-ratio of the box was approximately 1:1.6, the Golden Ratio
- Height of the box was kept low to enhance the **Asian Inspired** theme
- Router-mortised brass quadrant hinges were used to attach the lid
- Attached side panels incorporated the deep mortises required for the quadrant hinges
- Similar interlocking joint frames were used at the top and bottom of the box
- Box and frame dimensions produced a uniform  $1/16$ " reveal around the base of the box
- The lid and the bottom of the box consisted of bookmatched panels
- The bottom panel was inset into  $1/8$ "W x  $1/8$ "D blind dadoes in the bottom frame
- The small, tapered feet were made safely on the table saw with unusual fixturing and a setup method using a 1-2-3 gage block(See end of Newsletter for a tutorial on this process)

To aid in milling the tapered side panels of the box, a combination jig was used to resaw the parts on the bandsaw and drum sand them to finished dimension.



Spacer strips were used to support the parts and accommodate dual stacked feather boards. The parts were secured to the jig with small strips of double back tape.



With the part still attached to the jig, the handle/guard was removed from the front of the jig and the part was smoothed to thickness through the drum sander.

A few tricks were used to try to counteract the cupping tendency of the thin pieces of 2 x 4 stock. The kiln dried 2 x 4 was kept inside the house in a heated room for about a month before milling. According to his CAD drawing dimensions, **Paul** rough milled the 2 x 4 into pieces approximately  $1 \frac{1}{2}$  times finished thickness and again kept them inside the house for a couple of weeks to dry further and allow them to cup. Before milling to size, the stock was

drum sanded to finished thickness, which flattened them and removed the cupping. This technique seemed to remove most of the cupping problem on the final parts.

To use up some available shop material, **Paul** used liquid (not hot) hide glue to attach all of the parts. This glue sands nicely and doesn't seem to leave surface discoloration or objectionable joint lines with this particular wood species.

Multiple coats of clear **Deft Gloss and Semigloss Lacquer** (rattle cans) were used as the project finish. A coat of buffed paste **Carnauba** wax completed the box finishing, providing a more durable wax coating than the more common **Johnson's** paste wax.

The bottom of the box interior was covered by a separate panel which had red adhesive backed velvet applied. This material, marketed by **Rockler**, was fairly easy to work with and complemented the warm tones of the Douglas Fir box.

**Paul** noted that this project was challenging, but a lot of fun – especially devising techniques and fixturing to simplify the construction and milling of the parts. He hopes to use this experience and lessons learned to build a couple of similar hardwood boxes in the near future. Stay tuned.....

## *Note from the Editor*



We were pleased to see a good attendance at the 2 x 4 Challenge meeting, even though we only had six contest entries.

As in previous Challenges, it was really great to see the variety of projects, ingenuity of design, excellence of execution, and diversity of inspirational sources behind the projects. What a great opportunity to learn new things from our own members.

When asked about the low rate of participation in the Challenge, some of our newer members gave us some valuable feedback, expressing that they felt intimidated by the skill levels of our more experienced members – feeling that as beginners they just couldn't compete. I understand your dilemma, having felt that very same way myself – weren't we all beginners at one time? However, I have found the members of the Association to be very gracious, supportive and encouraging, and willing to offer constructive comments and suggestions. Like me, I am sure all of you "Just want to learn how to do it better next time!" Thank you folks, we really appreciate your candid answers to our inquiry. We want to encourage all of our members to feel like they can bring their projects to show their level of skill development, no matter whether they are beginners or more advanced woodworkers. We are here to help each other.

In response, long time member, **David Beyl**, suggested that next year we should have multiple categories for the Challenge, based upon each member's own perceived experience level, such as **Beginner**, **Intermediate**, and **Advanced**. Great idea, **David** – thanks for suggesting it! The Steering Committee will adopt that idea for next year's contest and develop the necessary procedures to support it.

Happy Woodworking,

Paul

# **Northwest Woodworkers Association Sponsors**

We appreciate the generous support provided by our NWWA sponsors, from providing member discounts on purchased items to providing state of the art venues for us to conduct our monthly meetings. Thank you, Sponsors!

## **Blackstock Lumber**

1039 Elliot Ave. W.  
Seattle, WA 98119  
10% Contractor Discount

## **Crosscut Hardwoods**

4100 – 1<sup>st</sup> Avenue South  
Seattle, WA 98134  
10% Member Discount

## **Edensaw Woods**

8032 S. 194<sup>th</sup> St.  
Kent, WA 98032

## **IsGood Woodworks**

4660 E. Marginal Way S, Suite 7  
Seattle WA 98134  
10% Member Discount on Selected Services

## **Rockler Woodworking and Hardware – Northgate**

832 NE Northgate Way Seattle, WA 98125  
10% Member Discount (not valid on sale items and power tools)

## **Rockler Woodworking and Hardware – Tukwila**

345 Tukwila Parkway  
Tukwila, WA 98188  
10% Member Discount (not valid on sale items and power tools)

## **Woodcraft Supply**

5963 Corson S.  
Seattle, WA 98108  
10% Member Discount (not valid on sale items, power tools and workbenches)

# **Northwest Woodworkers Association Contacts**

**Membership**—Allen McCall

**Treasurer**—Chris Green

**Secretary**—Jan Erickson

**Raffle**—Herb Stoops

**Webmaster**--- Tom Howorth [thoworth@gmail.com](mailto:thoworth@gmail.com)

**Newsletter Editor**--- Paul Stoops [pmstoops@comcast.net](mailto:pmstoops@comcast.net) 253-804-3209

**Photographer**— Scott Wilson

## **Steering Committee**

Bill Bond [williamcbond@comcast.net](mailto:williamcbond@comcast.net)

Chris Green [chrisandrenegreen@gmail.com](mailto:chrisandrenegreen@gmail.com)

Allen McCall [allen.mccl@gmail.com](mailto:allen.mccl@gmail.com)

Herb Stoops [hcstoops@comcast.net](mailto:hcstoops@comcast.net)

Paul Stoops [pmstoops@comcast.net](mailto:pmstoops@comcast.net)

We encourage our members to contact any of the above individuals with questions, comments, or items that may be of interest to the membership.

In addition, please visit our website and forum: <http://www.nwwoodworkers.org>

# TABLE SAW SETUP -- EASY AS 1-2-3

## A Tutorial About Making Small Parts Safely

### Background:

Making the **Asian Inspired Box** for the **Northwest Woodworkers Association 2015 2 X 4 Challenge** required the fabrication of four small wooden box feet. A number of members asked how such small pieces could be accurately and safely made on a table saw, so I have prepared this tutorial to describe this process, which was performed without any numerical measurements to set up the table saw fence for the multiple cuts.

**The Task:** Fabricate four identical tapered wooden feet, approximately 1 inch high x 13/16 inch square from a 2 x 4 stock blank.

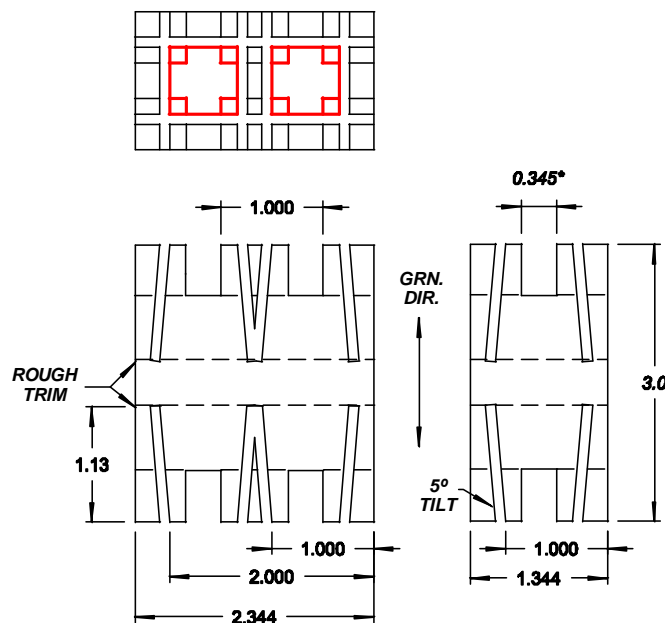
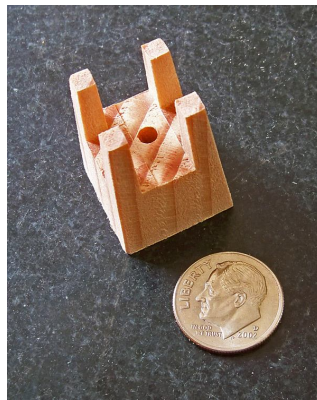

**BOX FOOT BLANK**



## A Different Approach:

As with most fabrication operations, there are many ways to accomplish the same task. I developed this particular set of operations, recognizing that there are other ways that would work equally well. I decided to document these procedures to demonstrate a different way of approaching table saw setup operations, which others might find useful for their applications.

In order to ensure the uniformity of the parts, I designed them on my CAD program such that they could be made by performing multiple identical operations on the same stock blank cut from a Douglas Fir 2 x 4, without having to change the table saw fence position. Constrained by the size of the 2 x 4 dimensions, I decided to make one pair of parts from each end of the blank, separated by a short waste section to enable subsequent parting and other operations.

The 0.345" wide x 0.500" deep intersecting slots in the top of each box foot were sized to accommodate the lower frame members of the Asian Inspired Box design. The slots were made in two passes using a 0.250" wide Box Cutting Blade set to ensure square corners at the edges of the slots. Alternatively, my standard dado set could have been used to make the slots in a single pass, but I find the "bat ears" produced in the corners of dados made by this method objectionable for highly visible joints.

The 5° taper on each side of each part was made with a standard table saw blade. After completion of all of the dados and angled cuts, the box feet were cut to rough length on the table saw to separate them from the stock blank. The two pairs of parts were subsequently mounted to a jig and trimmed to design length on the table saw and then passed through a drum sander to ensure smoothness and uniformity.

## Tooling:

Upon analyzing the design of the stock blank and the table saw setup operations required to make the parts, I discovered that the task was ideally suited for performing table saw fence setup operations using gage blocks and shop made spacers, eliminating numerical measurements (except for blade height) and the tolerances and risk that goes with them – from misread measuring scales, transposed numbers, etc. – to which I sometimes seem to be predisposed.....! :-)

To that end, I purchased an inexpensive pair of precision ground steel **1-2-3 gage blocks** (which cost less than a typical router bit!) and fabricated two wooden spacers, accurately milled to design thickness within 0.001". While 1-2-3 gage blocks are a standard tooling item in all machine shops, I have never heard of them being used in woodworking. Checked with my digital calipers, the blocks measured within 0.001" of design dimension on all three sides – obviously a much higher degree of accuracy than required for this task, but a nice feature to guarantee consistency and uniformity of results. A side benefit of using the 1-2-3 gage block was the ability to space the table saw fence farther from the cutting blade, providing better access and visibility.

Two hardwood spacers were also accurately milled on my drum sander to 0.406" and 0.501" thicknesses, respectively to aid in stock blank positioning for making all of the dado cuts. The spacers are not required for the angle cuts.



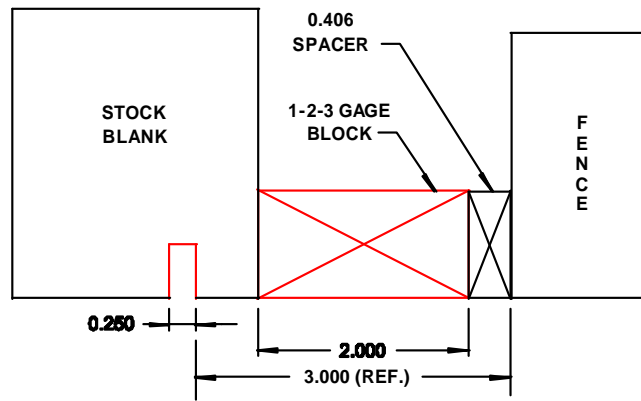

**FIRST DADO PASS SETUP**

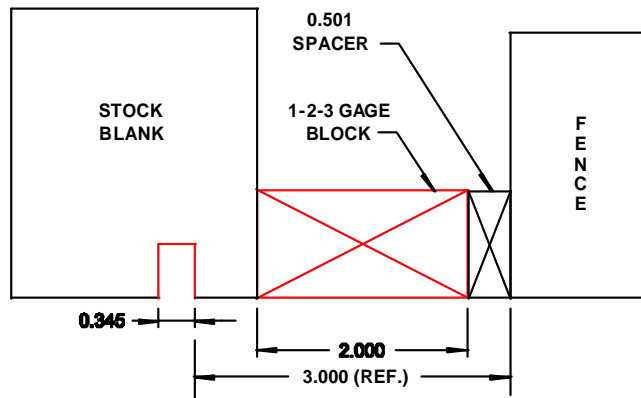

**SECOND DADO PASS SETUP**

**The most important aspect of this unique setup approach was using the 1-2-3 gage block to establish a fixed tablesaw fence position and accurate index surfaces for both the dado and sawing operations.**

This was accomplished by placing one end of 3" side of the 1-2-3 gage block against the fence and the other against the cutter/blade tooth set closest to the fence. The use of the spacers and the various orientation of the 1-2-3 gage block accomplished the correct stock blank positioning for the multiple cuts.

The other factor which enabled measurement free processing was the accurate milling of the stock blank. In accordance with my CAD drawing, I used my drum sander to easily and accurately mill the thickness and width of the stock blank to 1.344" and 2.344" respectively, as verified by my digital calipers. The noncritical length of the blank was 3".

### **Part Positioning and Safe Cutting Practices**

Since this task involved such small parts, all of the sawing operations were planned and executed with special attention to part positioning and safe cutting practices. All of the cuts were made with the stock blank firmly positioned against the saw table and the gage block and securely clamped to a sacrificial fence attached to the face of my table saw miter gage. These

measures enabled cutting with my hands on the miter gage handle, away from the cutting path and safely out of danger. The gage block/spacers were used as position stops to establish the stock blank location for clamping. The **1-2-3 gage block** was removed before each cutting operation, ensuring unobstructed travel of the miter gage. In addition, the saw was turned off after each cutting operation to enable safe handling of the parts and tooling during each subsequent setup operation.

In addition, final parting of the box feet from their waste material was done with the parts screwed to a saw fixture, which located the parts and secured them during the sawing operations and subsequent final smoothing on my drum sander.

In process photos incorporated in this document demonstrate the part positioning and safe cutting practices.

### **Preliminary Dimensional Verifications:**

Stock blank design dimensions: 1.344" thick x 2.344" wide x 3" long (noncritical)



**Verifying Stock Blank Thickness**



**Verifying Stock Blank Width**

Spacer design thicknesses: 0.406" and 0.501"



**Verifying Spacer Thickness**

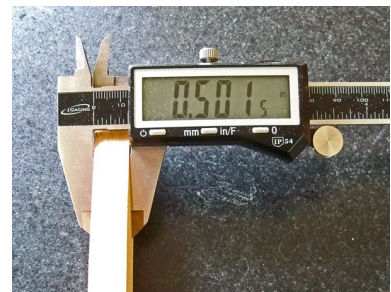

**Verifying Spacer Thickness**

## Making the Dados:

### Step 1 – Setting the table saw fence position

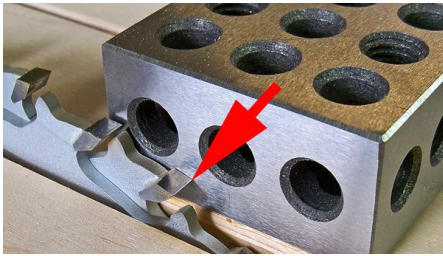

### **UNPLUG OR DISCONNECT THE POWER FROM THE SAW!**

The table saw fence position is established by placing one end of the 2" face of the 1-2-3 gage block against the fence and moving the fence until an *inside cutting tooth* on the fence side of the blade just makes contact with the face of the gage block. This spaces the fence ***exactly*** 3.000" from the blade. Locking the fence in this position establishes the basic index position for all of the subsequent dado cuts.

Step 2 – Set the blade height to 0.50", per part design. Confirm by measurement of a test cut.

### Step 3 – Making the first crosswise dado cut



Place the 0.406" spacer against the fence and the 3" side of the 1-2-3 gage block against the spacer as shown in the photo. Place the stock blank on end with the edge of the blank against the edge of the gage block and clamp to the sacrificial miter gage fence, *carefully positioning the clamp where it will not contact the blade*. Remove the gage block.

Turn on the saw and make the cut through stock blank and the back of the sacrificial fence – this will aid positioning the clamp for subsequent cuts. Turn off the saw and unclamp and remove the stock blank.



This photo shows the results of the first dado cut.

### Step 4 through Step 7 – Completing the initial crosswise dado cuts

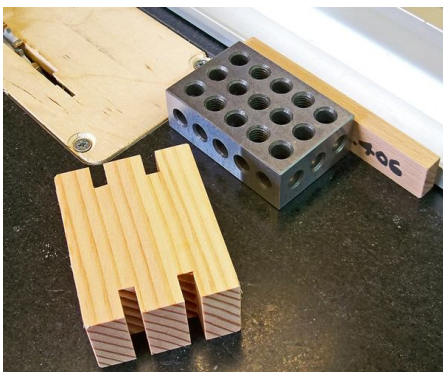

The remaining three initial dado cuts are made in exactly the same manner as shown in Step 3. The stock blank is rotated horizontally for the second cut and vertically and horizontally for the last two cuts. The same spacer and gage block orientation are used for all cuts.

### Step 8 – Making the initial second pass crosswise dado cut

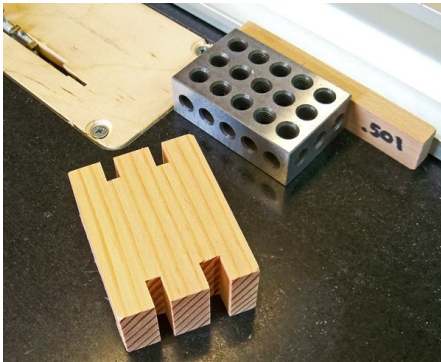

The second pass dado cuts widen the initial 0.250" wide dados to the design requirement of 0.343". For these cuts, remove the 0.406" spacer and replace it with the 0.501" spacer. Other than the spacer replacement, the setup, stock blank positioning and cutting operations are identical to those shown in Step 3.

The resulting cut is shown on the lower right of the photo.

### Step 9 through Step 11 – Completing the second pass crosswise dado cuts

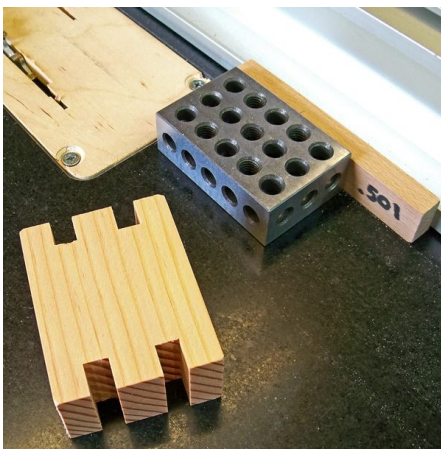

As with the first set of dado cuts, the remaining three dado cuts are accomplished by rotating the stock blank both horizontally and vertically between cuts, indexing the stock blank against the edge of the 1-2-3 gage block (along with the 0.501" spacer).

The completed second pass crosswise cuts are shown in the photo.

### Step 12 – Making the initial endwise dado cut



The setup for this initial endwise dado cut is exactly the same as described in Step 3 except that the wide surface of the stock blank is indexed against the edge of the gage block. The 0.406" spacer is used against the fence.

After clamping, **mark the surface against the gage block** for use in the next operation.

I used a different clamp for this operation because the total thickness to be clamped exceeded the capacity of the toggle clamp previously used. Given that one handed friction clamps are not as secure as screw-actuated clamps, the latter would be a better choice.

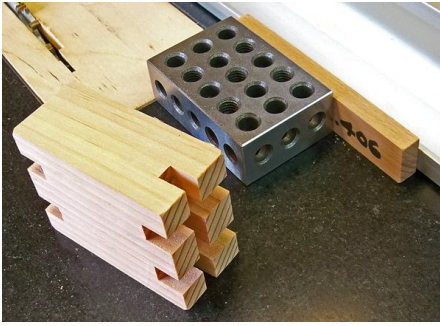

This is the appearance of the stock blank after the initial endwise dado cut.

### Step 13 – Completing the second endwise dado cut

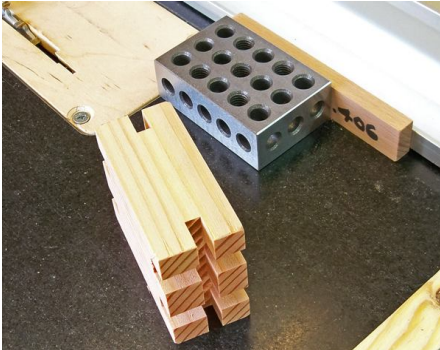

The second endwise dado cut should be made with the marked face of the stock blank against the gage block.

The stock blank after completion of the second endwise dado cut should be as shown in the photo.

Note that this initial dado is *not centered* on the thickness of the stock blank. Centering of the dado will occur in the next operation.

### Step 14 and Step 15 – Widening the endwise dado cuts

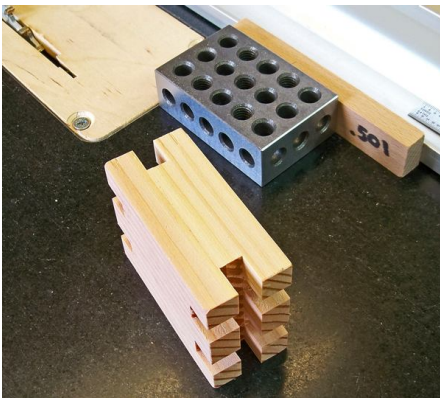

After changing the spacer from the 0.406" to the 0.501" spacer, the dados on both ends of the stock blank are widened from 0.250" to the 0.343" design value using the same indexing setup in Step 12.

#### **IMPORTANT SPECIAL NOTE:**

To ensure centering of the finished dado on the thickness of the stock blank, the marked side of the blank should face the gage block. (See Step 12)

After clamping the stock blank to the miter gage fence, and removing the gage block, and before turning on the saw, slide the blank forward to the cutter and visually check the location of the cut to be made. This second pass should remove material on the side of the dado closest to the gage block.

Reversing the part orientation could produce an erroneous cut, making the part unusable.

After this second pass cut is made, the widened dado should be centered on the thickness of the stock blank as shown.

## Verifying the dado cuts

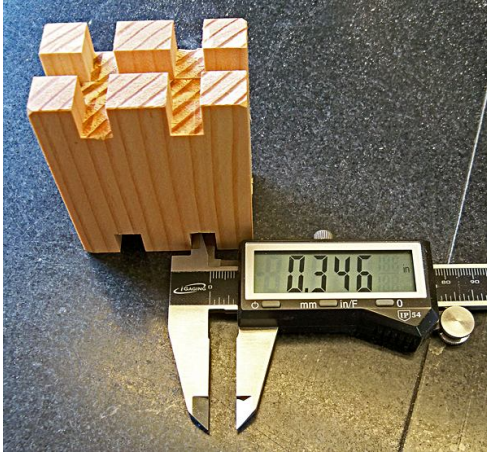

## Making the Angle Cuts:

The design of the box feet requires a 5° angle cut on each side of the part. These cuts are made with a standard table saw blade, either standard or thin kerf. Kerf width is not a factor since the inside edge of the cuts define the edge of the part, placing the kerf in the waste material.

### Step 1 – Setting the table saw blade tilt angle



### **UNPLUG OR DISCONNECT THE POWER FROM THE SAW!**

The easiest and most accurate method of setting up the blade tilt to accomplish the angled cut is by the use of an angle cube, such as one made by Wixey, IGaging, Beall, and others.

### Step 2 – Setting the table saw fence position

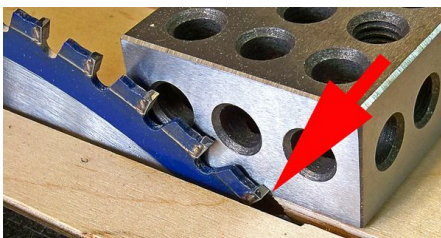

As with the setup for the dados, the **1-2-3 gage block** is used to establish an **exact** 3.000" distance between the fence and the cutting edge of the blade. This setback is accomplished by placing the 2" face of the gage block against the fence and moving the fence until an **inside cutting blade tip** just contacts the face of the gage block, **at the exact place where the blade passes into the table saw insert**. This fence position is used for all of the angled cuts.

Step 3 – Set the blade height to 1.13", per part design. Confirm by measurement of a test cut.

#### Step 4 – Making the first interior crosswise angled cut

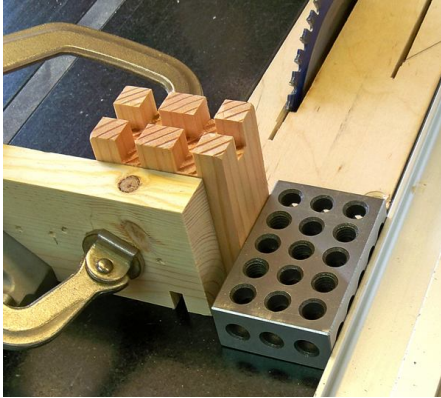

Place the 3” side of the 1-2-3 gage block against the fence as shown in the photo. No spacers are required for any of the angled cuts. Place the stock blank on end with the edge of the blank against the edge of the gage block and clamp to the sacrificial miter gage fence, carefully positioning the clamp where it will not contact the blade. Remove the gage block.

Turn on the saw and make the cut through stock blank and the back of the sacrificial fence – this will aid positioning the clamp for subsequent cuts. Turn off the saw and unclamp and remove the stock blank.

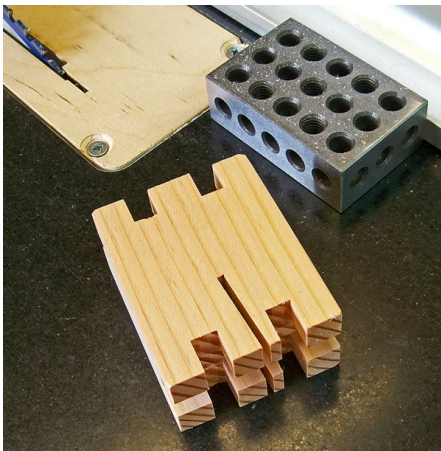

The first interior crosswise angled cut should appear as shown in the photo.

#### Step 5 through Step 7 – Completing the interior crosswise angled cuts

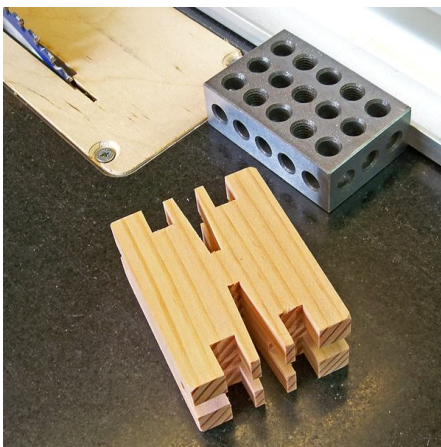

The remaining three interior crosswise angled cuts are made in exactly the same manner as shown in Step 4. The stock blank is rotated horizontally for the second cut and vertically and horizontally for the last two cuts. The same gage block orientation is used for all cuts.

Note that where two interior angled cuts intersect, a narrow wedge of waste material is eliminated.



## Step 8 – Making the first outside crosswise angled cut

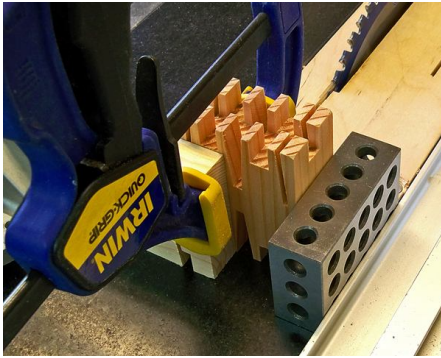

Although not shown in the photo, the sacrificial fence should be repositioned to just clear the face of the gage block, to provide maximum clamping area.

Rotate the 1-2-3 gage block so that the 1" wide face contacts the saw table and the 3" side of the gage block contacts the fence as shown in the photo. No spacers are required for any of these angled cuts. Place the stock blank on end with the edge of the blank against the face of the gage block and clamp to the sacrificial miter gage fence, carefully positioning the clamp where it will not contact the blade. Remove the gage block.

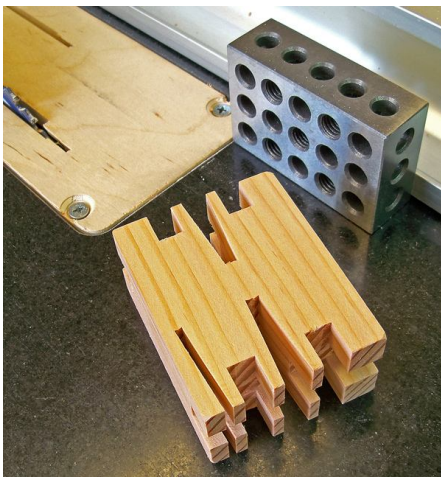

Turn on the saw and make the cut through stock blank and the back of the sacrificial fence. This will aid positioning the clamp for subsequent cuts. Turn off the saw and unclamp and remove the stock blank.

The first outside crosswise angled cut should appear as shown in the photo.

## Step 9 through Step 11 – Completing the outside crosswise angled cuts

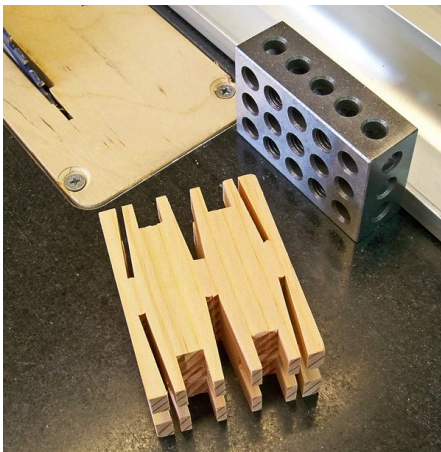

The remaining three outside crosswise angled cuts are made in exactly the same manner as shown in Step 8. The stock blank is rotated horizontally for the second cut and vertically and horizontally for the last two cuts. The same gage block orientation is used for all cuts.

This set of cuts completes all of the crosswise cuts. Note that the outline of the four box feet is starting emerge.

## Step 12 – Making the first endwise angled cut

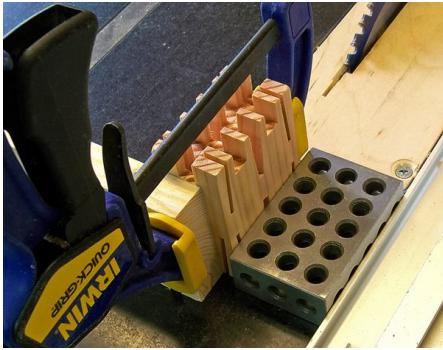

Place the 3” side of the 1-2-3 gage block against the fence as shown in the photo. No spacers are required for any of the angled cuts. Place the stock blank on end with the face of the blank against the edge of the gage block and clamp to the sacrificial miter gage fence, carefully positioning the clamp where it will not contact the blade. Remove the gage block.

Turn on the saw and make the cut through stock blank and the back of the sacrificial fence – this will aid positioning the clamp for subsequent cuts. Turn off the saw and unclamp and remove the stock blank.

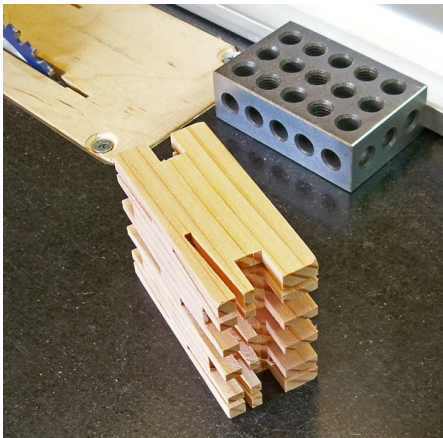

The first endwise angled cut should appear as shown in the photo.

## Step 13 through Step 15 – Completing the endwise angled cuts

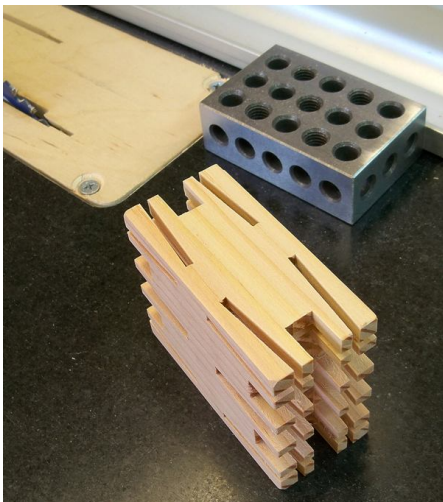

The remaining three endwise angled cuts are made in exactly the same manner as shown in Step 12. The stock blank is rotated horizontally for the second cut and vertically and horizontally for the last two cuts. The same gage block orientation is used for all cuts.

This set of cuts completes all of the endwise cuts. Note that the outline of the four box feet is now clearly visible.

## Proof of the Pudding (as the saying goes..... !)

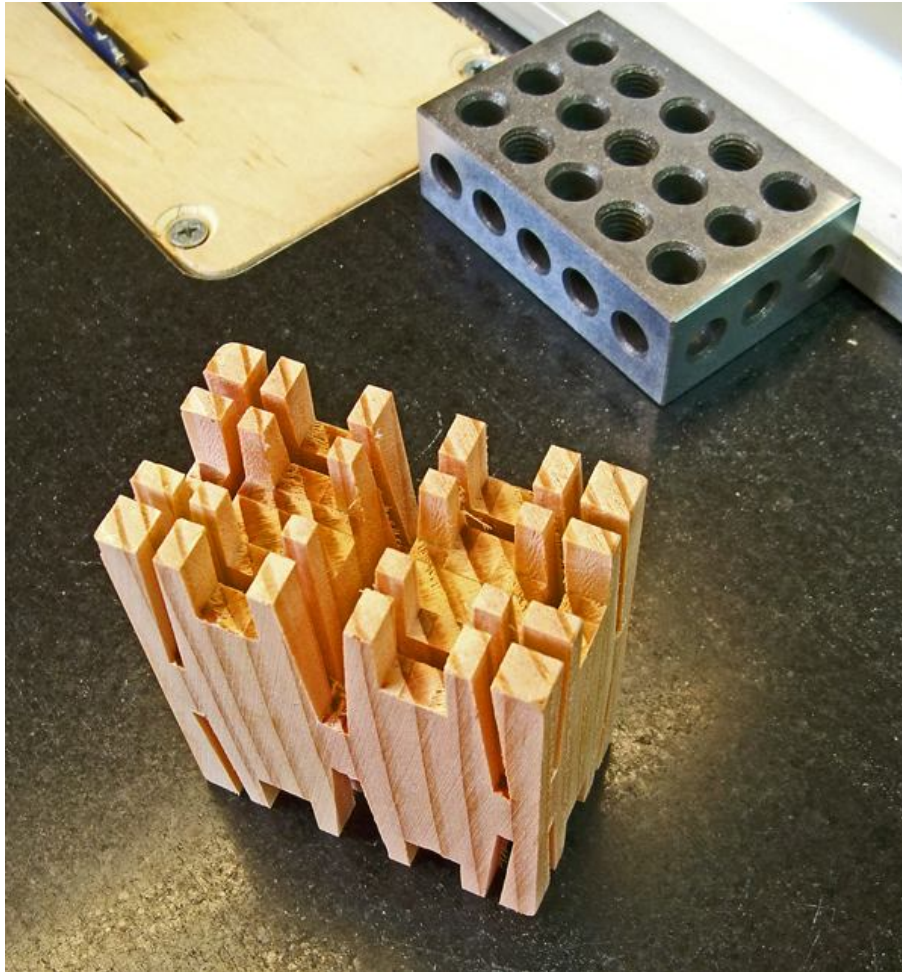

**The Completed Box Foot Blank**

The completed Box Foot blank clearly demonstrates the effectiveness of this unique approach to table saw setup. Especially note the uniformity of the four vertical “prongs” on the end of each of the two Box Feet in the center of the blank. As closely as I could measure with a digital caliper, the end of each “prong” was 0.140” square +/- 0.005”!! And as noted previously, the widths of the dados were essentially right on the design values, ensuring a good fit with the mating **Asian Inspired** Box components.

Based upon the operational simplicity and accurate results, I would definitely classify this gage block method of table saw setup a **KEEPER** for applications involving multiple parts and repetitive operations! I hope that some of our clever woodworkers will also discover other useful applications for this technique.

But of course the **Star of the Show** is the **1-2-3 Gage Block** – a standard tool borrowed from the world of our machinist brethren, suited for many different setup and gaging applications, and worthy of a place in every woodworker’s tool collection.

## Final Operations

### Step 1 – Dividing the stock blank

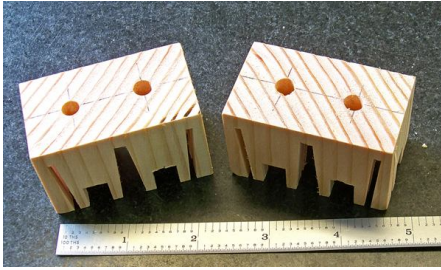

The blank was then divided in half and screw holes were drilled and counterbored at the center of each foot. Although the bands of hard grain made it difficult to keep the small diameter drill centered in the hole, any hole misalignment would not create a problem on final installation. A cork pad to be applied to the bottom of each foot would cover the hole.

Care was taken to ensure that the depth of the counterbore would be sufficient to miss the screw heads during the final length trimming operations.

### Step 2 – Fixturing the blank halves for trimming



After removing the outer waste material with the bandsaw, each blank half was securely attached to a combination saw/sanding fixture (made from 2 x 4 scrap to securely nest the parts) using #6 x  $\frac{3}{4}$ " sheet metal screws, selected for also attaching the feet to the Asian Inspired Box.

Pan head screws were selected because flat head screws exert a radial force when tightened, which can easily split soft wood end grain like Douglas Fir.

### Step 3 – Setting them free



The blank halves were then cut free from the remaining waste material on the table saw to a length slightly greater than the final design dimension.

Attaching the blank halves to the fixture with screws enabled safe processing of the small parts during the final trimming operations. Note how the tapered edge of the parts and the dado nest securely with the fixture,



The set of box feet fresh from the table saw, trimmed to the approximate 1" design length and ready for final sanding to length.

#### Step 4 – Sanding to final length

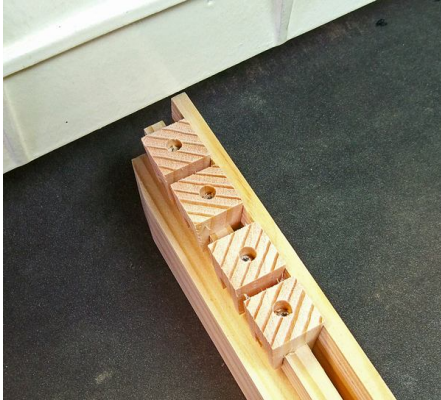

Without removing them from the combination sawing/sanding fixture, the set of box feet were processed through my drum sander to smooth the sawn ends.

Dual use jigs and fixtures are a very efficient way to minimize the time required to build tooling, and minimize tolerance errors sometimes produced by differences in multiple tools and repositioning parts.



After sanding, the box foot ends were smooth and a uniform length.

The box feet were then removed from the fixture and final hand sanded to smooth the edges and break the sharp corners.

Although not shown, a chamfer was subsequently hand applied to the bottom corners of each of the feet as a final operation.

#### Task completed!



## Finding a home



**Asian Inspired Box**  
**Winner of the NWWA 2015 2 x 4 Challenge**  
**Crafted by Paul M. Stoops**

Tutorial written by Paul M. Stoops, Northwest Woodworkers Association, March 31, 2015  
Please address any corrections, questions, or comments to me at [pmstoops@comcast.net](mailto:pmstoops@comcast.net)